

DF606CG



FEATURES

Cook at higher highs and lower lows with six dual-stacked, sealed burners that produce up to 20,000 Btu and deliver as low as 300 Btu

Rely on a 16,000 Btu infrared charbroiler for more succulent steaks, chops, and burgers

Rely on a 15,000 Btu infrared griddle to sear burgers, stir-fry vegetables, and more

Clean up splashes and spills easily with the seamless, sealed, black porcelain-coated burner pans

Assures predictably delicious results with a variety of modes including Convection Roast, Proof, and Dehydrate

Operate easily with a control panel that rotates out of sight when not in use

Control heat and airflow expertly as dual convection creates just the right cooking environment for everything from Cornish hens to cherry pie to butternut squash

Leave nothing to chance. Our temperature probe alerts you when your dish has reached the desired temperature for worry-free, delicious results

Includes options such as self-clean, delayed start, timed cook, Sabbath mode, and more

Re-ignites flame automatically with our spark ignition system for improved temperature control and added safety

Move pots and pans effortlessly across the continuous cast-iron grates

Find your kitchen style with a choice of iconic red, black, or brushed stainless steel control knobs

See food clearly with bright interior halogen lights and large double-panel glass door windows

ACCESSORIES

11" Cutting Board

2-Burner Wok Grate

3 1/4" Front Leg Covers

3 1/4" Rear Caster Covers

3 3/4" (95) Front Leg Covers

3 3/4" Rear Caster Covers

30" Bake Stone Kit

30" Broiler Pan

30" Full-Extension Ball-Bearing Oven Rack

4 1/4" Front Leg Covers

4 1/4" Rear Caster Covers

4 3/4" Front Leg Covers

4 3/4" Rear Caster Covers

48" and 60" Black Knobs

48" and 60" Red Knobs

48" and 60" Stainless Steel Knobs



KNOB OPTIONS



TOP CONFIGURATION

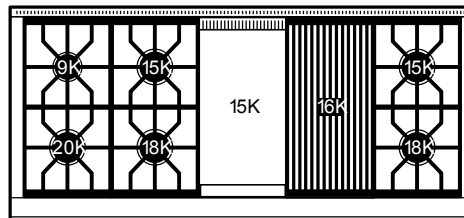

RANGETOP SPECIFICATIONS

- 1 - 9,200 Btu burner
- 1 - 20,000 Btu burner
- Stainless-steel island trim riser included
- 2 - 15,000 Btu burners
- 2 - 18,000 Btu burners
- 1 - 16,000 Btu charbroiler
- 1 - 15,000 Btu griddle
- Stainless-steel charbroiler and griddle covers

Dehydration Kit

Filler Trim

Griddle Cleaning Kit

Griddle Cleaning Pads

Griddle Cleaning Solution

Oven Rack Set (3)

Premier Baking Sheet

S-Grates

Temperature Probe

Stainless steel, brass or chrome bezels

5" and 10" stainless steel risers, and 20" riser with shelf

Accessories available through an authorized dealer.

For local dealer information, visit [subzero-wolf.com/locator](https://www.subzero-wolf.com/locator).

Specifications are subject to change without notice. This information was generated on July 7, 2020. Verify specifications prior to finalizing your cabinetry/enclosures.

PRODUCT SPECIFICATIONS

Model	DF606CG
Dimensions	60 1/8"W x 36 7/8"H x 29 1/2"D
Oven 1 Usable Capacity	2.8 cu. ft.
Oven 1 Overall Capacity	4.5 cu. ft.
Oven 2 Usable Capacity	2.8 cu. ft.
Oven 2 Overall Capacity	4.5 cu. ft.
Door Clearance	19 1/2"
Electrical Supply	240/208 VAC, 60 Hz
Electrical Service	50 amp dedicated circuit
Gas Supply	3/4" ID line
Gas Inlet	1/2" NPT female

DIMENSIONS

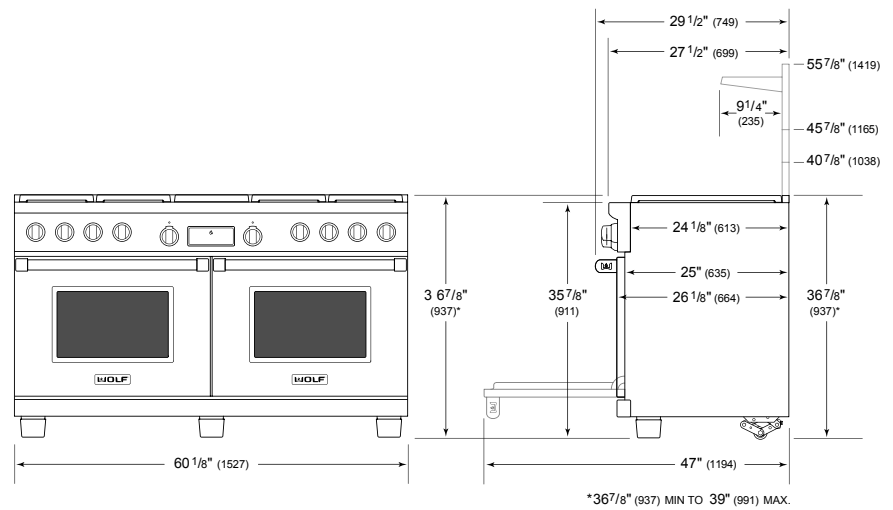

ELECTRICAL

GAS

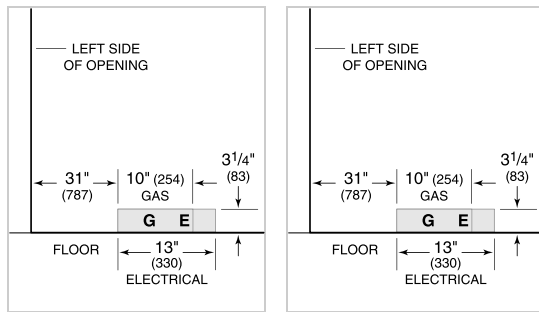

NOTE: Dimensions in parenthesis are in millimeters unless otherwise specified

STANDARD INSTALLATION

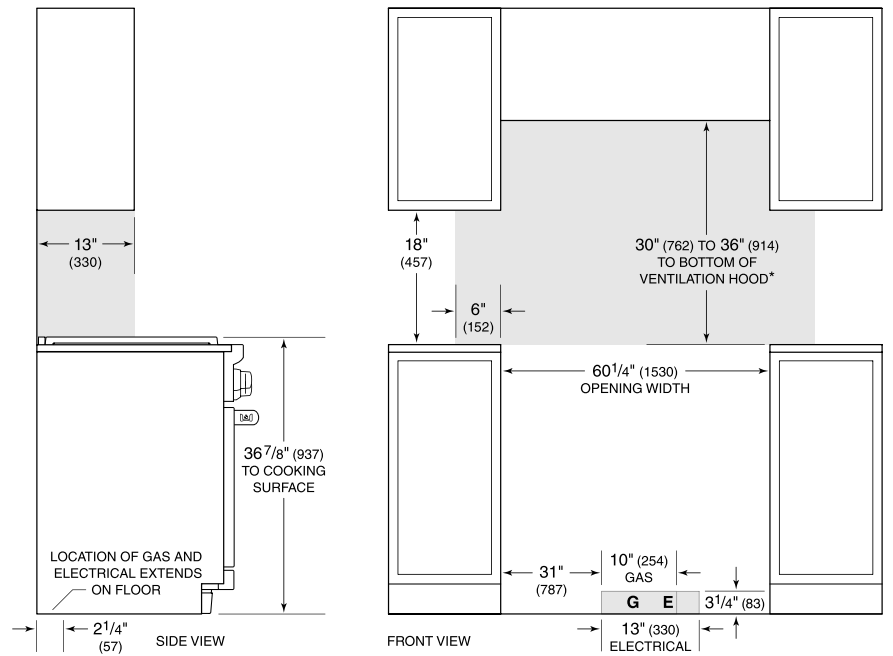

*Without ventilation hood, 36" (914) minimum clearance countertop to combustible materials, 44" (118) for charbroiler.

NOTE: Shaded area above countertop indicates minimum clearance to combustible surfaces, combustible materials cannot be located within this area.

For island installation, 12" (305) minimum clearance back of range to combustible rear wall above countertop.